



Installation and Operating Instructions

Raypak Water Heaters

Part 1: Safety warning

Part 2: Models B0109 & 147 NCH, NCO

Part 3: Models B0197, 277, 347 & 427 NCO, NCM

Part 4: Warranty

CONTENTS

Part 1: For Your Safety

Part 2: Models B0109 and 147 NCH, NCO

Section 1. Installation Instructions
Section 2. Owners Operating
Instructions

Part 3: B0197, 277, 347, 427 NCO, NCM

Section 1. Installation Instructions
Section 2. Owners Operating
Instructions

Part 4: Warranty

Date of Installation: _____ // _____ // _____

Model No. _____

Serial No. _____

Installed by: _____

Purchased from: _____

This Installation and Operating Instructions Manual is provided with the necessary information for the proper installation, operation and maintenance of your Raypak Heater. Please review and follow these procedures carefully. Keep this manual in a safe and accessible place for easy reference in the future.

For your safety do not operate this appliance before reading this instruction booklet.

WARNING

Improper installation, adjustment, alteration, service or maintenance can cause injury or property damage. For assistance or additional information consult your Raypak distributor, qualified installer, or service agency.

WHAT TO DO IF YOU SMELL GAS?

DO NOT try to light any gas appliance

DO NOT touch any electrical switch.

Turn off the gas supply at the gas meter

Immediately, call your gas supplier or licensed gasfitter.

NOTE: Some gases are heavier than air and it may be necessary to check for gas leaks at floor level.

CAUTION

DO NOT Operate this appliance before reading this instruction booklet.

DO NOT Place articles on or against appliance.

DO NOT Store chemicals or flammable materials in the same room as this appliance.

DO NOT Store chemicals or flammable materials, on, or spray aerosols near this appliance.

DO NOT Operate with panels, covers or guards removed from appliance.

DO NOT Enclose this appliance (applies to external models only).

DANGER

Water temperatures above 45 Degrees Celsius can cause severe burns.

Children, disabled and elderly persons are at the highest risk of being scalded.

Feel water before bathing or showering and supervise where necessary.

Keep this manual in a safe and accessible place for easy reference in the future.

This Installation and Operating Instructions Manual is provided with the necessary information for the proper installation, operation and maintenance of your Raypak Heater.

Please review and follow these procedures carefully.

Model No. Serial No. Installation Date

Part No. 209130.5: Effective 08/01/2001 (Replaces: 01/10/2000)



CAUTION!

Ceramic Firetile Refractory is used in Raypak Heaters

Possible risks of irreversible effects

Harmful by inhalation

May be irritating to the skin, eyes and respiratory system.

WHEN HANDLING

- Minimise airborne dust.
- Wear an approved mask or respirator.
- Avoid any contact with the skin and eyes.
- Wear suitable loose-fitting, long-sleeved clothing.
- Wear gloves and eye protection.
- Consult Occupational Health and Safety Authority for any further information.

AFTER HANDLING

- Rinse any exposed skin areas with clean water.
- Wash work clothing separately.

FIRST FIRING OF HEATER

- Fumes and smoke may be produced.
- Avoid breathing fumes, ventilate area to clear.
- Production of smoke should cease within 30 minutes

REMOVAL OF USED PRODUCT

- Wear an approved mask. Over-exposure to dust formed after service may cause respiratory disease since cristobalite, a form of crystalline silica may be formed above 900 degrees Celsius.
- Consult Occupational Health and Safety Authority for further information regarding removal of used ceramic fibre lining.

Raypak Water Heaters

Part 2: Models B0109 and
147 NCH, NCO



PART 2 - SECTION 1 - INSTALLATION INSTRUCTIONS

MODEL 109 & 147

Before you commence the installation:

1. **Read these instructions in full!**
2. **Check that the heater you have been supplied is suitable for the type of installation and the gas that is available. The gas supply pressure must be between the minimum and maximum as shown on the heater data plate.**

These instructions are provided to ensure the correct installation and operation of your Raypak Pool Heater. Should any questions arise regarding the specifications, installation, operation or servicing of this heater, we suggest that your local representative or Rheem Customer Service be consulted.

Raypak heaters utilise a finned copper tube heat exchanger resulting in a low water content and reduced "stand by" heat losses. Therefore a pump of sufficient capacity to match the heater model must be installed in the system

Raypak heaters are Australian Gas Association approved and are designed for either indoor or outdoor installation simply by fitting the appropriate indoor draft hood or outdoor stackless top. Check that the correct top for your installation has been supplied.

All electrical, gas piping, gas connection and flueing of the heater must only be undertaken by a properly authorised person. The installation must comply with local gas, AS5601/AG601 and electrical codes and/or statutory body codes and regulations.

INSTALLATION PROCEDURES - INSPECTION OF EQUIPMENT

Check the heater and associated equipment for any damage and notify your local representative or Raypak for any further instructions.

DO NOT INSTALL OR START UP ANY RAYPAK SUPPLIED PRODUCT THAT HAS BEEN DAMAGED, WITHOUT FIRST CONSULTING RAYPAK AS ANY DAMAGE OR FAULTS CAUSED BY UNAUTHORISED START UP MAY NOT BE COVERED BY OUR WARRANTY.

HEATER LOCATION

The heater should be located so that any possible water leaks will not cause damage to

any adjacent areas or structures. When such locations cannot be avoided, it is recommended that a suitable drain pan, adequately drained, be installed under the appliance.

This pan should not restrict combustion airflow.

The heater must be mounted on a level non-combustible base such as a concrete slab, concrete plinth, steel plate etc. Heaters must not be installed on carpeting.

CLEARANCES

The front of the heater must not be obstructed by any gas or water piping, electrical conduits, trees, fences, filtration equipment, etc.

Minimum Clearance for non-combustible materials: (mm)

Model	Rear	Front	LH Side	RH Side	Ceiling
109	50	600	600	300	1200
147	300	750	300	300	1200

Minimum Clearances for combustible materials (all Models) in mm.

	Indoor Heater	Outdoor heater
Horizontal	600	600
Vertical	1200	Unobstructed

For servicing purposes allow at least 600mm in front of the heater for burner tray removal and increasing the water connections side to 450mm would assist with heat exchanger servicing.

COMBUSTION / VENTILATION AIR

Indoor model heaters must only be installed in a protective enclosure or properly constructed plant room with adequate ventilation in accordance with AS 5601/AG 601 Gas Installation Code.

Ventilation shall be via two permanent openings directly to outside, one at an upper level and one at low level.

The minimum free area provided by each vent shall be as calculated by using the chart below unless otherwise stated in AS 5601/AG 601.

Minimum free ventilation area in square cms.

Heater Model	Area	Heater Model	Area
109	327	147	441

Note: The minimum dimension of any opening shall be 6mm.

Warning: Air supply to the heater room must not be affected by mechanical exhaust vents

located in other parts of the house or building, such as kitchen or bathroom fans, spa blowers, etc.

Mechanical exhaust vents may create a negative pressure in the heater room that can become a hazard by asphyxiation, explosion or fire.

Caution: Do not store chemicals or flammable materials in the same room or near this heater. Do not use aerosols near this heater whilst it is in operation.

FLUEING

The correct draft hood must be fixed to the top of the heater and connected to a properly constructed flue, vented to the outside using only approved fittings.

Reduction of the flue diameter or alteration to the draft hood voids all warranty. Where flueing may be difficult, please contact Rheem/Raypak for advice, we will have solutions, particularly where a fan assisted flue may be the answer.

The weight of the flue must not rest on the heater draft diverter, the flue must be self-supporting and be fitted with a disconnection section (bolted sleeve) to enable the heater top and draft diverter to be removed easily, for servicing.

Where practicable the flue should run vertically. Lateral (raised above horizontal) is acceptable but the run of a flue shall not exceed 50% of total flue height and shall be designed to rise not less than 20 mm per 1 m run. The flue must be terminated with an approved cowl.

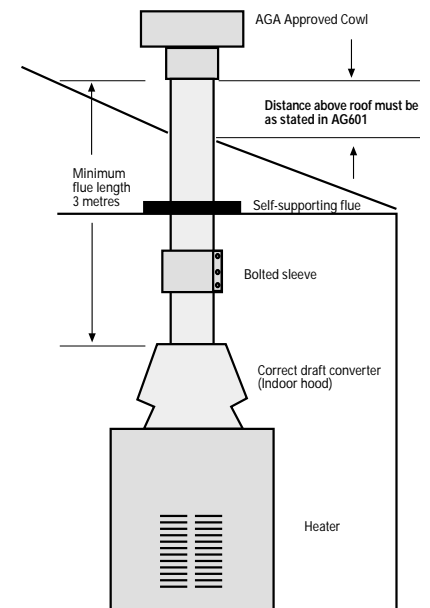

OUTDOOR HEATERS

Must not be installed inside any roofed structure or under eaves, roof overhangs, or pool decks. It should also be at least 1500mm, in any direction from any window or fresh air opening.

When installing the heater on a raised base, please make sure that the base material is solid and filled in. (e.g. If steel mesh decking is used, a suitable plate material must be used to fill in the perforations.) This is very important, as excessive drafts must not be able to enter the unit from directly underneath.

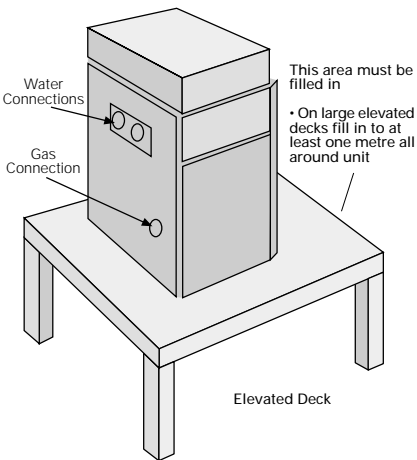

HIGH WIND CONDITIONS

On some rare occasions or in areas where high winds frequently occur, it may be necessary to locate the heater a minimum of one (1) metre away from high vertical walls, or to install a wind break so that the heater is not in the direction of prevailing winds.

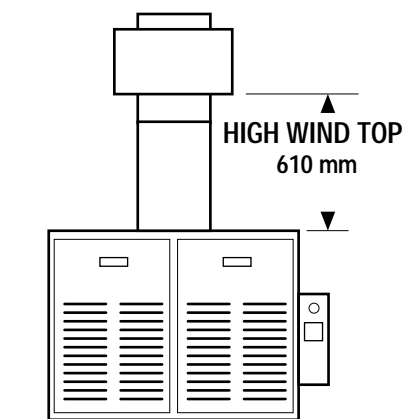

In areas of "constant extreme winds", it may be necessary to replace the standard low profile outdoor top with a HIGH WIND top (at extra cost).

The HIGH WIND TOP serves the same function as the low profile outdoor hood and should be installed in accordance with the same clearance requirements.

HOOD CONVERSION

To convert a heater from an outdoor configuration to an indoor configuration.

1. Remove the outdoor hood and put to one side.
2. Fit indoor hood (draft diverter) squarely on heater and screw into pre drilled holes.
3. Return outdoor Hood to supplier.

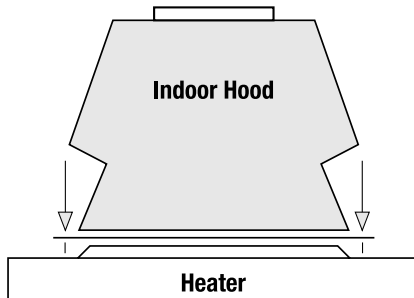

GAS SUPPLY

The gas supply pipe must be sized to give sufficient pressure and volume for the correct operation of the heater. The gas line must be fitted with an isolation valve. Consult AS 5601/AG 601 for further details.

TESTING GAS LINE

Caution: The gas supply must be isolated from the heater during pressure testing of the gas fitting line. Dissipate the test pressure before reconnecting to the heater.

Failure to follow this procedure may result in damage to the gas valve. Over pressured valves that are damaged are not covered by our warranty.

The heater and its gas connection must be thoroughly leak tested before placing in operation. Use only soapy water and a manometer for leak testing.

DANGER! Do not use an open flame to check for gas escapes.

WATER CONNECTIONS AND SYSTEM PIPING

The heater must be installed to AS 3500.4 and/or local codes.

For Typical piping systems and heater applications we recommend that Rheem be consulted.

Raypak heaters do have some special requirements and if you are not familiar with Raypak products we can save you unnecessary inconvenience!

Water pipe connections to the heater are - 109 NCH 25mm (1") B.S.P. 147 NCH, NCO 32mm (1.25") BSP.

Do not reduce the pipework size and heater water connections without allowing for any friction loss which will occur. Low water flow will cause damage to the heater and system components.

Please install pipework to heater using approved fittings and isolating valves that will allow easy disconnection for any future maintenance requirements.

PUMP SELECTION

In order to obtain the best possible hydraulics in your system, you must select the correct size water-circulating pump. The factory installed pump supplied with the "EP" (expansion pack) models should be satisfactory for most systems.

Refer to Flow Rate and Pressure Drop chart and allow for the system head pressure when sizing the pump. When the total system head pressure exceeds 4.5m for a 109 and 4.1m for a 147, a secondary pump must be installed.

We recommend that the pump be selected to provide a 15 to 20°C temperature difference between the heater water inlet and outlet, when the heater is at full firing rate.

If a system water temperature rise in excess of 20 Deg C is required, please contact Raypak for advice. Systems with multiple zones may require additional pump(s).

WATER FLOW RATE AND PRESSURE

	10°C Rise		15°C Rise		20°C Rise	
Model	l/sec	kPa	l/sec	kPa	l/sec	kPa
109	0.5	5.0	0.4	4.0	0.3	3.0
147	0.8	5.0	0.5	3.0	0.4	3.0

COLD WATER MAKE-UP SUPPLY

Hydronic Heaters: We recommend that a cold water feed regulator (Pressure Reducing Valve) be installed and set at 50 kPa minimum pressure. Backflow prevention in accordance with A.S. 3500.1 may be required or alternatively a cold feed (header) tank may be used. The minimum recommended height above the heater is five (5) metres. Most systems operate at 100 kPa COLD.

Domestic Hot Water Heaters: These heaters are normally connected to a storage tank and the cold water supply must be filled with a Pressure Limiting Valve. If the water supply pressure exceeds the pressure indicated on the storage tank (eg. normal city water will require a 550 kPa Pressure Limiting Valve)

PIPING

Heating Heaters: We recommend that all high points of the system be vented or fitted with automatic air vents. The design of the system must be such that the heater is provided with adequate water flow and pressure at all times. On radiator or heating systems where thermostatic valves will vary the water flow, then a suitable by-pass valve must be installed to guarantee the correct heater water flow.

Domestic Hot Water Heaters: If the heater is supplied as part of a package, including the tank and pump, the installation must comply with the drawing provided. Failure to observe this requirement may result in an ineffective hot water capacity or damage. For installation of the heater to an existing storage vessel we suggest that advice be sought to eliminate possible problems. We have produced a Hot Water Manual, which will be of assistance. Contact Rheem for your free copy.

IMPORTANT: When installing a new heater to an old or existing system, it is a Raypak requirement that the system and its equipment be thoroughly inspected and if necessary, drained and flushed out with clean fresh water, before the new heater is connected. Failure to do this may cause blockages and/or heater damage which is not covered by warranty and any damage caused would result in extra costs to repair etc. IF THERE IS ANY DOUBT ABOUT THE SYSTEM, DRAIN AND FLUSH AS A PRECAUTION.

WATER QUALITY

The standard finned copper tube heat exchanger has proved to be very resilient and capable of operating for many trouble-free years on most reticulated water supply systems. However, should your installation be in an area where

corrosive or hard water is present, contact Rheem prior to commencing installation.

PRESSURE RELIEF VALVE(S)

There are three (3) standard pressure relief valves available, 310 kPa (45 PSI), 415 kPa (60 PSI) and 860kPa(125PSI).

When sizing the valve, static head pressure must be taken into account to ensure that the PRV will not release during the heat-up cycle.

When the heater is connected to a storage cylinder for domestic hot water applications, a correctly sized and pressure rated PTR valve MUST be fitted to the storage cylinder (See also, High Limit under Commissioning.)

ELECTRICAL WIRING

The maximum electrical power consumption of the heater is: 240 Volts AC, approx. 60 watts, 50/60 Hz. A normal 10 or 15 Amp power circuit should be suitable.

Access to the electricals on the 147 model is gained by removing the screws located just above the front door opening and then allowing the controls cover to drop downward.

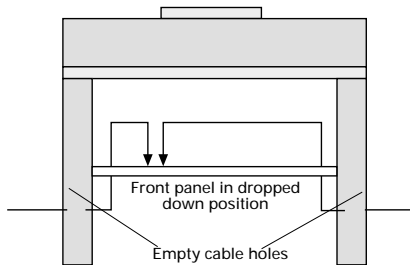

Access to the electricals on the 109 model is achieved by removing the front door and then removing the screws, then sliding out the junction box, which is located on the floor underneath the burner. The heater must be properly earthed and Raypak recommends most highly the installation of an RCD (Residual Current Device) for added electrical safety.

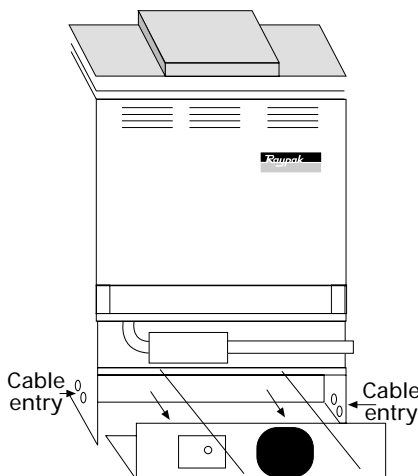

The Heater Must Not Be Able To Operate Without The Circulating Water Pump Running.

The heater 240 Volts supply must be interlocked via the auxiliary contacts of the pump contactor (relay) etc, or alternatively, the power supply for the pump and the heater must operate off the same circuit and its isolation switch.

PART 2 - SECTION I - INSTALLATION INSTRUCTIONS

ELECTRICAL CONNECTION ETC.

A flow switch is not an interlock and must not be used as one!

A pump run on timer (Economaster) is standard so that at any time the heater is no longer required, the heater shuts off and the pump continues to operate for at least ten (10) minutes.

For servicing purposes we suggest that the isolation switch/powerPoint be installed as close as possible to the heater.

If there is any control wiring etc. which is not isolated by the main switch then a suitable warning label must be affixed to the heater which will also direct the service person to the isolation switch etc. for that particular wiring. (Eg. more than one isolation switch is required to turn off the power supply, extra switch(es) on switchboard etc.)

CAUTION: DO NOT LOCATE CABLES IN FRONT OR UNDERNEATH THE BURNER. Consult Rheem for advice if unsure.

Where cables or conduit, trunking etc. are mounted on the heater casing, please keep at least 10mm air gap from the heater casing to eliminate possible overheating.

Do not locate cables etc. where they will obstruct or restrict access covers, doors etc.

INITIAL START-UP AND COMMISSIONING

1. Ensure that the heater is clean and the surrounding area is clear of all combustible and flammable materials.
2. Remove all liquids and chemicals from the plant room and check that combustion air openings are not obstructed. Chemicals must not be stored in plant rooms. This could be extremely dangerous and damaging to the heater.
3. Fill the system with water and expel any air as required.
4. Purge all air from gas supply piping. Caution LP Gas is heavier than air and sinks to the ground. Exercise extreme care in lighting heater in confined areas.
5. Test ALL gas connections for leaks, using soapy water and a manometer (**NOT A NAKED FLAME**).
6. Check that power is available and the circulation pump is running.
7. Follow lighting instructions in Owner's Operating Instructions section.
8. Set the heater thermostat and/or controls to desired temperature:

On the 109 model, simply dial up the required temperature.

On the 147 model, the model CTX032Y01

thermostat is fitted. It is programmed to operate in the heating mode and the only adjustments that should normally be required are the set points ("set"), which are the two water temperatures that you require, (eg. SE.1 switches the heater off completely and SE.2 switches the heater from High Fire to Low Fire.)

To adjust these set points: -

- Turn on the power supply to the heater.
- Digital display will show the actual water temperature.
- Press the "set" button, SE.1 will be displayed for two seconds.
- Press the "set" button again, for the set point of System Temp,
- Press the "UP (ALM)" or "DOWN (PRG)" button to select the desired temperature.
- Press the "set" button to save the setting and SE.1 will be displayed.
- Press the "UP (ALM)" or "DOWN (PRG)" button and SE.2 will be displayed.
- Press the "set" button again and the Set Point for Low Fire will be displayed.
- Press the "UP (ALM)" or "DOWN (PRG)" button to select the desired temperature,
- Press the "set" button to save the setting and SE.2 displays will be displayed.
- Press the "DOWN (PRG)" button to display SE.1.
- Leave the control and it will return to display actual temperature.

We suggest SE.1 - 82 Deg. C and SE.2 - 75 °C for a heating system. However, it may be necessary to increase SE.2 if there is an unacceptable variation in room temperature.

9. Set High Limit at approximately 15°C above the operating temperature. On open systems, (using a cold feed tank) the temperature setting must not exceed 100°C to avoid boiling the water.

10. Check the operation of any other safety devices or indicators etc., if fitted.

11. Check and reset burner gas pressures (if required, see below).

TO OPERATE AS ON-OFF CONTROL, ADJUST LOW FIRE TO THE SAME PRESSURE AS HIGH FIRE, IT MAY BE NECESSARY TO ALSO MOVE THE THERMOSTAT BULB (or Water Sensor) TO THE INLET SIDE OF THE HEATER IF CYCLING OF BURNER IS EXCESSIVE. CONTACT RHEEM FOR FURTHER ADVICE IF NEEDED.

12. Verify that the heater and the circulator pump are interlocked so that the heater will not operate without water flow.

It is quite normal for the heater to produce some smoke and possible condensation for the

first thirty (30) minutes of firing when new.

Warning - Should overheating occur or the gas fail to shut off, turn off the gas isolation valve adjacent to the heater and then examine the unit or call for assistance. During heat up the burner flame should be blue and have a well-defined pattern.

PLEASE FULLY INSTRUCT THE END USER ON THE OPERATION OF THIS APPLIANCE AND MAKE SURE THAT THEY ARE GIVEN THIS OPERATING AND INSTALLATION MANUAL.

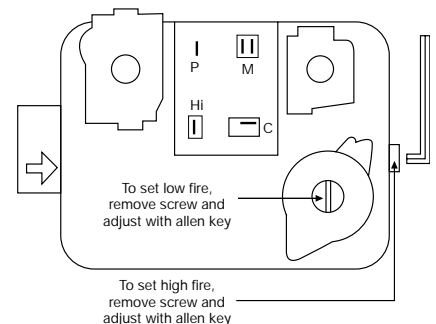

Factory settings are:

Natural Gas

Low Fire: 250 Ps, High Fire - 775 Pa.

LPG (Propane)

Low Fire- 650 Pa, High Fire - 2750 Pa.

To convert to On-Off control, adjust Low Fire the High Fire pressure.

Note: On the 109 Model, the Gas Control is upside down to this drawing.

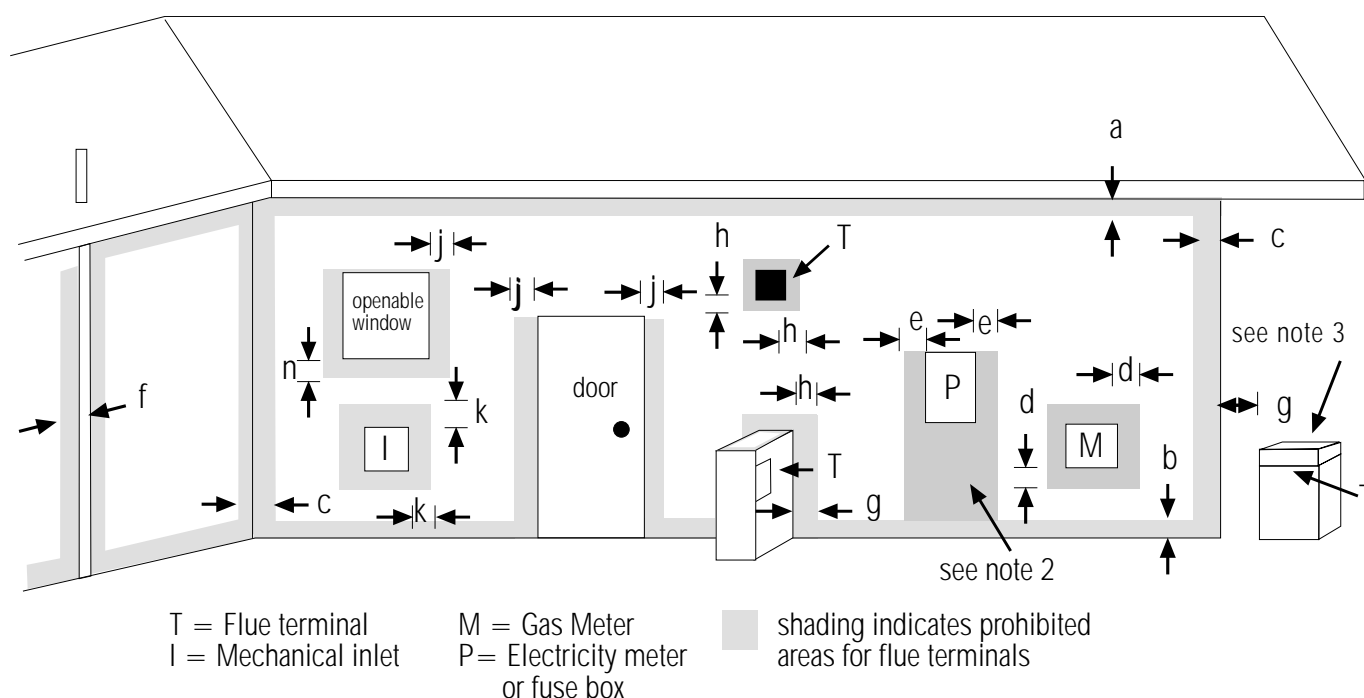

Ref	Item	Minimum clearances (mm)	
		Natural Draught	Fan Assisted
a	Below eaves, balconies and other projections • Appliances up to 50 MJ/h input • Appliances over 50 MJ/h input	300	200
		500	300
b	From the ground, above a balcony or other surface.	†300	300
c	From a return wall or external corner.	†500	300
d	From a gas meter (M)	1000	1000
e	From an electricity meter or fuse box (P)	500	500
f	From a drain pipe or soil pipe.	150	75
g	Horizontally from any building structure † or obstruction facing a terminal.	500	500
h	From any other flue terminal, cowl or combustion air intake.	†500	300
j	Horizontally from an openable window, door, non-mechanical air inlet or any other opening into a building with the exception of sub floor ventilation. • appliances up to 150 MJ/h input • Appliances over 150 MJ/h input up to 200 MJ/h input1 • Appliances over 200 MJ/h1 • All fan-assisted flue appliances, in the direction of discharge.	500 1500 1500 1500	300 500 1500
k	From a mechanical air inlet, including a spa blower.	1500	1000
n	Vertically below an openable window, non-mechanical air inlet, or any other opening into a building with the exception of sub-floor ventilation. • Space heaters up to 50 MJ/h input • Other appliances up to 50 MJ/h input • Appliances over 50 MJ/h input and up to 150 MJ/h input • Appliances over 150 MJ/h input1	150 500 1000 500	150 500 1000 500

MINIMUM CLEARANCES

Minimum clearances required for balanced flue terminals, fan-assisted flue terminals, room-sealed appliance terminals or the terminals of outdoor appliances.

Notes:

- All distances are measured to the nearest part of the terminal.
- Prohibited area below electricity meter or fuse box extends to ground level.
- Where the flue terminal or a balanced flue appliance, a fan assisted flue appliance, a room sealed appliance or the flue terminal of an appliance designed for outdoor installation is to be installed under a covered area:
 - The covered areas to be open on at least two sides; and
 - The terminal is to be located to ensure a free flow of air across it is achieved.
- See AS 5601/AG 601, Gas Installations, for clearances required from a flue terminal to an LP Gas Cylinder. A flue terminal is considered to be a source of ignition.
- For appliances not addressed above approval shall be obtained from the Office of Gas Safety.

For further information contact the Office of Gas Safety. Telephone: 1800 652 563

Issued 21 July 2001 - Supersedes May 2000.

† - unless appliance is approved for closer installation.

PART 2 - SECTION I - INSTALLATION INSTRUCTIONS

FIRE RESISTANT MATERIALS

The below table contains materials that are known to comply with the requirements of the Gas Installation Code, AG 601, Appendix C. Other materials may also comply, check with the supplier.

Issued August 2000 - Supersedes February 2000

If further information is required, please phone 9341 3812 or 1800 652 563.

Proprietary name of material & minimum thickness required	M7AF Millboard (6mm)	Supalux (9mm) Monolux (12mm)	Bellis Board (9mm) Tacfire Insulation Board (9mm)	Promaect H (12mm)
Thermal Conductivity W/mk	0.11 (M7AF)	0.17 (Supalux) 0.26 (Monolux)	0.17 (Bellis) 0.175 (Tacfire)	0.23
Supplier	Thermal Ceramics 111-113 William Angliss Drive Laverton (03) 9930 0355	Tyco Services 47 Gily Road Notting Hill (03) 9538 7659 OR Mijell Enterprises 1 Bond Street Mordialloc (03) 9580 0211	Bellis Australia P/L 2/11 Havelock Road Bayswater (03) 9720 5100	Promat Fyregaurd 2/202 Lorimer Street Port Melbourne (03) 9645 3866

PART 2 - SECTION I - INSTALLATION INSTRUCTIONS

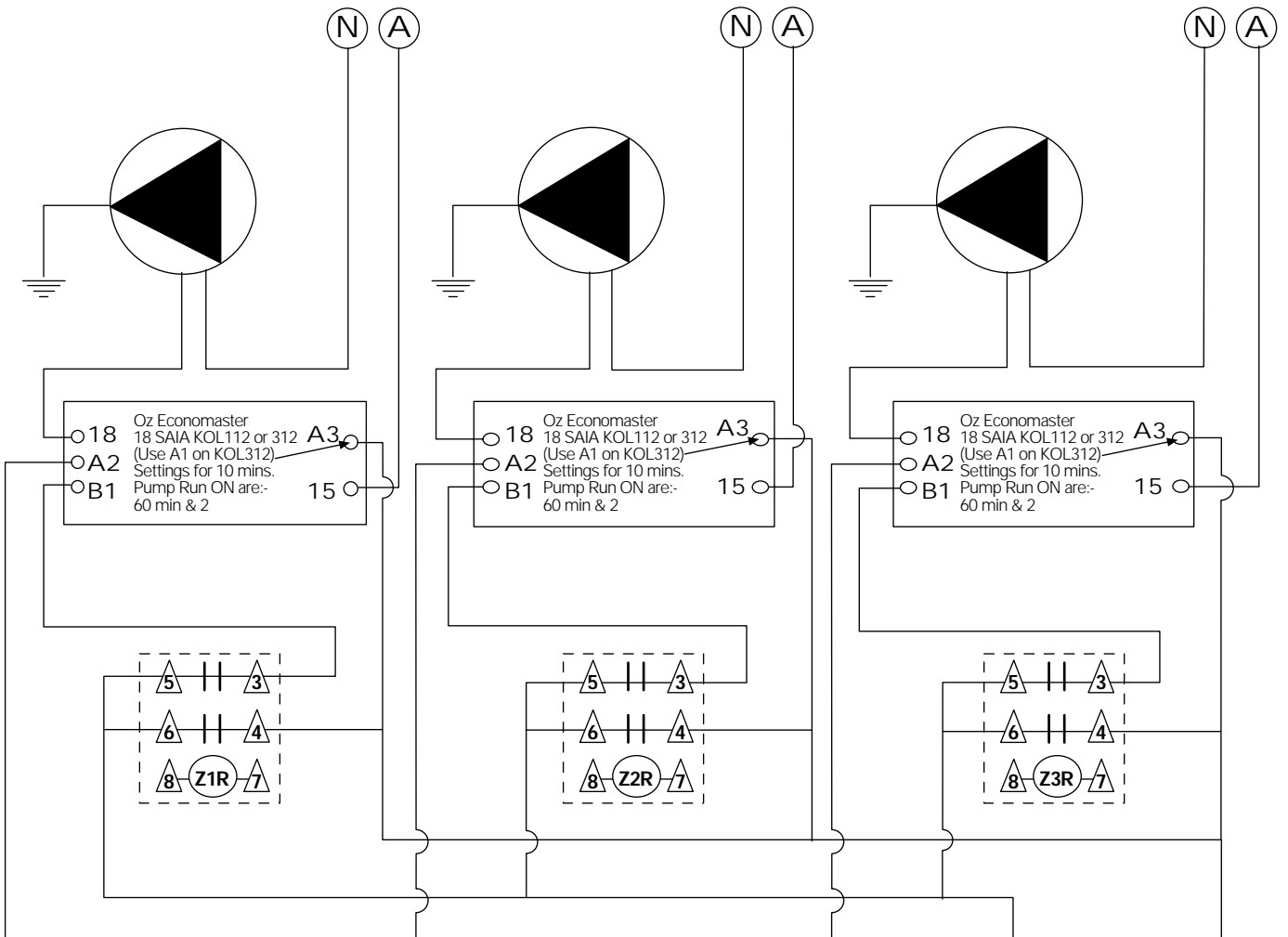

NOTES

- Z1R** Zone One Relay
- Z2R** Zone Two Relay
- Z3R** Zone Three Relay
- △** Relay Terminals
- 7** Relay Terminals
-  Water Pump

Relays are energised by Room Thermostat or Switch

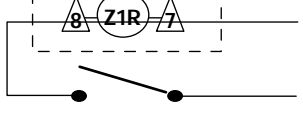

All wiring and mounting of components is by the installer

BE CAREFUL!
There is no limit to the amount of zones. However, make sure that the boiler transformer has enough capacity to power the relays and Oz Economasters. Another transformer will be necessary if that is the case.

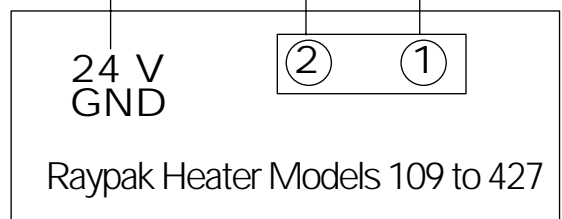

PART 2 - SECTION II - OPERATING INSTRUCTIONS

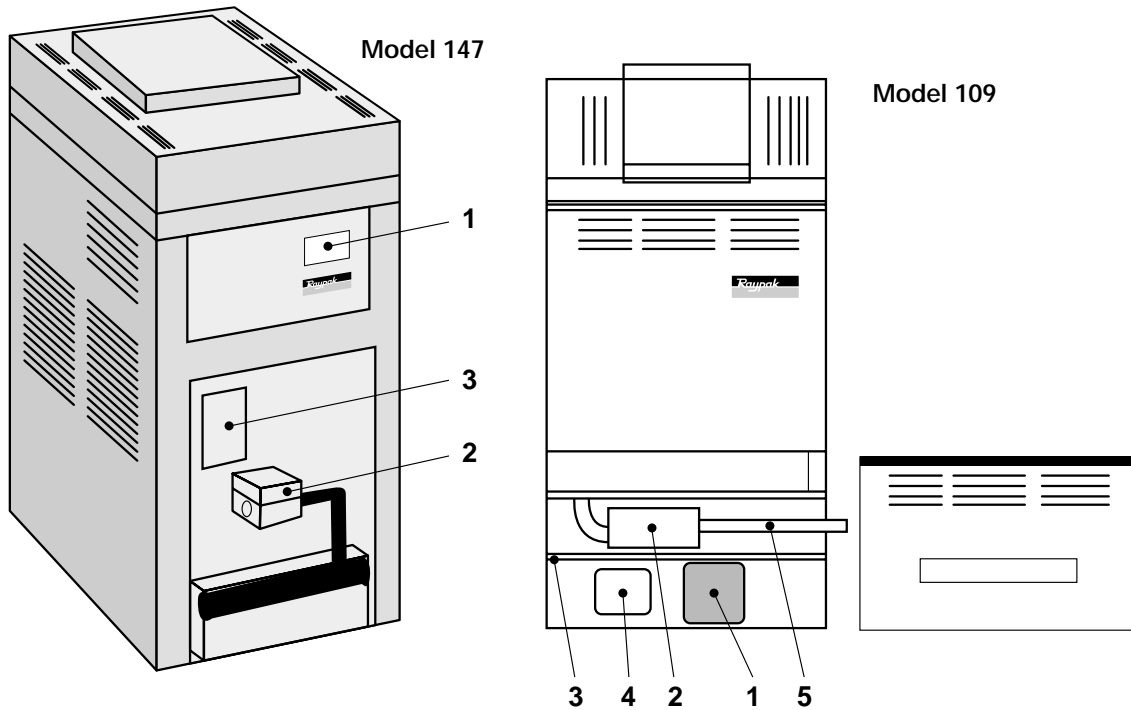

LOCATION OF CONTROLS

1. Operating Thermostat 2. Gas Control Valve 3. Data Plate 4. High Limit 5. Gas Connector

1. Operating Controls

Your new Raypak heater is fitted with High/Low/Off thermostat, which automatically controls the main electric gas valve. The purpose of this thermostat is to adjust the gas firing rate down to approximately 25% of full firing to allow for consistent water temperature on a heating system with radiators. The temperature of the system water is controlled by matching the dial to the required temperature on the 109 models or by adjusting the digital thermostat on the 147 models.

2. Gas Control

This device provides the gas supply to the burner. It is linked to the computerised ignition system and requires no adjustment by the user.

3. Data Plate

This provides all necessary information regarding model number, serial number, gas, water and electrical specifications, and other technical specifications for the installer and service technician.

4. High Limit

A manual reset high limit switch, will shut down the heater in the event of a fault with the temperature control. Note: The temperature setting of the high limit control and thermostat will be set by the installer at the time of commissioning, to suit the individual requirements of your system. Further adjustments should not be necessary or should not be altered without consultation with your installer.

In the event of an overheat of the system water temperature, the high limit will trip. This will shut off the heater. When the system water temperature has cooled sufficiently, the red button can be pressed, this will restart the heater. Should frequent resetting be necessary, a service technician should be called to check the system.

LIGHTING INSTRUCTIONS

Warning! If you smell gas do not attempt to light this appliance.

Do not use this heater if any part has been under water. Immediately call Rheem Service to replace any part of the control system that has been under water.

Ensure that the heater is clean and the surrounding area is clear of all combustible and flammable materials.

Remove all liquids and chemicals from the plant room and check that combustion air openings are not obstructed.

Chemicals must not be stored in plant room - this is extremely dangerous and damaging to the heater.

LIGHTING PROCEDURE.

1. STOP read the safety information.
2. Turn "OFF" any other electrical power to the heater.
3. Wait 5 minutes to clear out any gas.

STOP!

If you smell gas, follow safety instructions.

If you do not smell any gas continue ...

4. Remove the front door panel on models 109 only.
5. This heater is equipped with an ignition device that automatically lights the burners.
6. Don't attempt to light the burner by hand.
7. Set the thermostat to the desired temperature.
8. Replace front door panel.

9. Turn on all electrical power to the heater.

NOTE: If the heater will not operate, turn off the power supply, wait one (1) minute, turn the power supply back on. If heater still does not light, turn off gas and power supply and contact Rheem or your qualified service technician.

TOTURN OFF THE HEATER

1. Turn off the power switch.

EMERGENCY SHUT-DOWN

1. Turn "OFF" the power supply to the heater.
2. Turn "OFF" the gas isolation valve fitted close to the heater or the main gas supply.

AFTER START-UP

WARNING: Should overheating occur or the gas supply fail to shut off, turn off the gas isolation valve located adjacent to the heater turn off the power supply switch and call for assistance.

Operation of the heater without water circulation will result in rapid and severe damage to the heater.

VISUAL INSPECTION

With the heater on, remove the door and make a visual check of the burners. The flame should be blue with a well-defined pattern.

A yellow or floating flame indicates restricted air openings or incorrect orifice size. Should this occur, turn the heater off and contact your installer.

RECOMMENDED SERVICE PROCEDURES

It is a Raypak requirement that all Raypak supplied equipment is serviced at least annually.

In some installations, due to the appliance location and/or workload it may be necessary to perform a service every six months.

RECOMMENDED SERVICE PROCEDURE FOR ANNUAL SERVICE.

- Isolate gas, electricity and water as required.
- Remove access covers and door(s) as required.
- Disconnect and remove Burner Tray.
- Dismantle and clean pilot assembly(ies), including injector(s).
- Clean and re-align electrode(s) and/or flame rod(s) and /or thermocouple(s).
- Clean main burner injectors and burner bars as required.
- Inspect, repair if minor and clean combustion chamber.
- Report on any major combustion chamber damage.
- Inspect external area of heat exchanger, clean fins and repair if minor.
- Check water seal area and report any damage.
- Operate Pressure Relief Valve (if Fitted) manually to check that the drain is clear and the valve reseals.
- Refit Burner Tray and reconnect gas train etc.
- Perform gas soundness tests to the gas train.

(Any failures must be reported and repaired before recommissioning appliance.)

- Check all air vents and louvres, clean as required.
- Restore gas, electricity and water as required.
- Recommission unit, check and prove the operation of all safety devices.
- Check and monitor the operation of the appliance for at least ten (10) minutes.
- Refit access covers and doors as required.
- Clear and remove any dust and debris from the appliance and its immediate area.

RECOMMENDED SERVICE PROCEDURE FOR SIX MONTHLY SERVICE.

- Isolate gas, electricity and water as required.
- Remove access covers and doors as required.
- Visually inspect main burner and pilot, check operation if needed.
- If necessary, remove Burner Tray and service as required. (Refer to Annual Service).
- Check over the appliance thoroughly and report any damage immediately.

Raypak Water Heaters

Part 3: Models B0197, 277,
347 and 427 NCO, NCM



PART 3 - SECTION I - INSTALLATION INSTRUCTIONS

Before you commence the installation:

1. **Read these instructions in full!**
2. **Check that the heater you have been supplied is suitable for the type of installation and the gas that is available. The gas supply pressure must be between the minimum and maximum as shown on the heater data plate.**

These instructions are provided to ensure the correct installation and operation of your Raypak Pool Heater. Should any questions arise regarding the specifications, installation, operation or servicing of this heater, we suggest that your local representative or Rheem Customer Service be consulted.

Raypak heaters utilise a finned copper tube heat exchanger resulting in a low water content and reduced "stand by" heat losses. Therefore a pump of sufficient capacity to match the heater model must be installed in the system

Raypak heaters are Australian Gas Association approved and are designed for either indoor or outdoor installation simply by fitting the appropriate indoor draft hood or outdoor stackless top. Check that the correct top for your installation has been supplied.

All electrical, gas piping, gas connection, water piping and flueing of the heater must only be undertaken by a properly authorised person. as well as other requirements as necessary, the installation must comply with local gas AS5601/AG601, water AS 3500 and electrical codes AS/NZS 3000:2000 and/or statutory body codes and regulations.

INSTALLATION PROCEDURES - INSPECTION OF EQUIPMENT

Check the heater and associated equipment for any damage and notify your local representative or Raypak for any further instructions.

DO NOT INSTALL OR START UP ANY RAYPAK SUPPLIED PRODUCT THAT HAS BEEN DAMAGED, WITHOUT FIRST CONSULTING RAYPAK AS ANY DAMAGE OR FAULTS CAUSED BY UNAUTHORISED START UP MAY NOT BE COVERED BY OUR WARRANTY.

HEATER LOCATION

The heater should be located so that any possible water leaks will not cause damage to

any adjacent areas or structures. When such locations cannot be avoided, it is recommended that a suitable drain pan, adequately drained, be installed under the heater.

This pan should not restrict combustion airflow or servicing accessibility.

The heater must be mounted on a level non-combustible base such as a concrete slab, concrete plinth, steel plate etc. Heaters must not be installed on carpeting or the like.

CLEARANCES

Minimum Clearance for non-combustible materials: (mm)

Rear	Front	LH Side	RH Side	Ceiling
150	600	300*	150	1200

* The normal heater design is with the water pipe entry from the left hand side.

Minimum Clearances for combustible materials (all Models) in mm.

	Indoor Heater	Outdoor heater
Horizontal	600	600
Vertical	1200	Unobstructed

For servicing purposes allow at least 600mm in front of the heater for burner tray removal.

Increasing the water connections side to 450mm would assist with heat exchanger servicing.

COMBUSTION / VENTILATION AIR

Indoor model heaters must only be installed in a protective enclosure or properly constructed plant room with adequate ventilation in accordance with AS 5601/AG 601 Gas Installation Code.

The minimum free area provided by each vent shall be as calculated by using the chart below unless otherwise stated in AS 5601/AG 601.

Minimum free ventilation area in square cms.

Heater Model	Area	Heater Model	Area
197	585	227	825
347	1035	427	1275

Note: The minimum dimension of any opening shall be 6mm.

Warning: Air supply to the heater room must not be affected by mechanical exhaust vents located in other parts of the house or building, such as kitchen or bathroom fans, spa blowers, etc.

Mechanical exhaust vents may create a negative pressure in the heater room that can become a hazard by asphyxiation, explosion or fire.

Caution: Do not store chemicals or flammable materials in the same room or near this heater. Do not use aerosols near this heater whilst it is in operation.

FLUEING

The correct draft hood must be fixed to the top of the heater and connected to a properly constructed flue, vented to the outside using only approved fittings.

Reduction of the flue diameter or alteration to the draft hood voids all warranty. Where flueing may be difficult, please contact Rheem/Raypak for advice, we will have solutions, particularly where a fan assisted flue may be the answer.

The weight of the flue must not rest on the heater draft diverter, the flue must be self-supporting and be fitted with a disconnection section (bolted sleeve) to enable the heater top and draft diverter to be removed easily, for servicing.

Where practicable the flue should run vertically. Lateral (raised above horizontal) is acceptable but the run of a flue shall not exceed 50% of total flue height and shall be designed to rise not less than 20 mm per 1 m run. The flue must be terminated with an approved cowl.

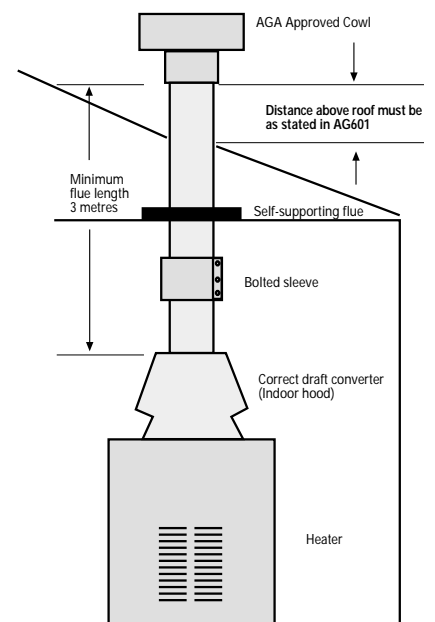

OUTDOOR HEATERS

Must not be installed inside any roofed structure or under eaves, roof overhangs, or pool decks. It should also be at least 1500mm, in any direction from any window or fresh air opening.

When installing the heater on a raised base, please make sure that the base material is solid and filled in. (e.g. If steel mesh decking is used, a suitable plate material must be used to fill in the perforations.) This is very important, as excessive drafts must not be able to enter the unit from directly underneath.

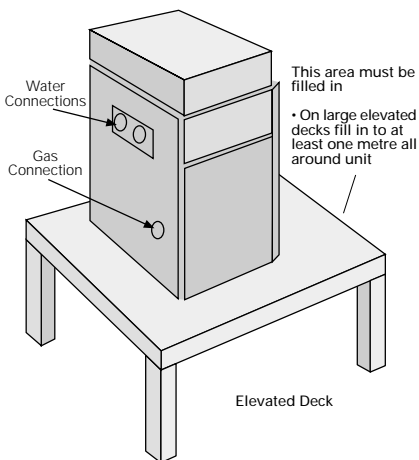

HIGH WIND CONDITIONS

The Raypak RB2100 series of heater has been subjected to wind tests of up to 90 km/h as part of the AGA approval process. However in areas where high winds can frequently occur, it may be necessary to locate the heater a minimum of one (1) metre away from high vertical walls, or to install a wind break so that the heater is not in the direction of prevailing winds.

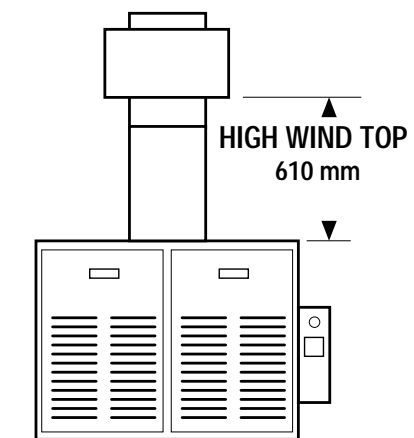

In areas of "constant extreme winds", it may be necessary to replace the standard low profile outdoor top with a HIGH WIND top (at extra cost).

HOOD CONVERSION

To convert a heater from an outdoor configuration to an indoor configuration.

Remove the counter sunk screws from the perimeter of the outdoor hood.

Remove outdoor hood and discard.

Install indoor flue connector plate to top of the heater and screw in position.

Fit draft diverter over the spigot and sit squarely on flue connector plate.

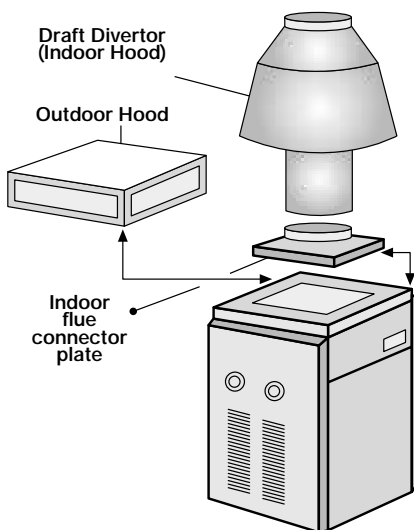

GAS SUPPLY

The gas supply pipe must be sized to give sufficient pressure and volume for the correct operation of the heater. The gas line must be fitted with an isolation valve. Consult AS 5601/AG 601 for further details.

TESTING GAS LINE

Caution: The gas supply must be isolated from the heater during pressure testing of the gas fitting line. Dissipate the test pressure before reconnecting to the heater.

Failure to follow this procedure may result in damage to the gas valve. Over pressured valves that are damaged are not covered by our warranty.

The heater and its gas connection must be thoroughly leak tested before placing in operation. Use only soapy water and a manometer for leak testing.

DANGER! Do not use an open flame to check for gas escapes.

WATER CONNECTIONS AND SYSTEM PIPING

The heater must be installed to AS 3500.4 and/or local codes.

For Typical piping systems and heater applications we recommend that Rheem be consulted.

Raypak heaters do have some special requirements and if you are not familiar with Raypak products we can save you unnecessary inconvenience!

The water pipe connections are 38mm BSP.

Do not reduce the pipework size and heater water connections without allowing for any friction loss which will occur. Low water flow will cause damage to the heater and system components.

Please install pipework to heater using approved fittings and isolating valves that will allow easy disconnection for any future maintenance requirements.

PUMP SELECTION

In order to obtain the best possible hydraulics in your system, you must select the correct size water-circulating pump. The factory installed pump supplied with the "EP" (expansion pack) models should be satisfactory for most systems.

Refer to Flow Rate and Pressure Drop chart and allow for the system head pressure when sizing the pump. When the total system head pressure exceeds 4.5m for a 109 and 4.1m for a 147, a secondary pump must be installed.

We recommend that the pump be selected to provide a 15 to 20°C temperature difference between the heater water inlet and outlet, when the heater is at full firing rate.

If a system water temperature rise in excess of 20 Deg C is required, please contact Raypak for advice. Systems with multiple zones may require additional pump(s).

WATER FLOW RATE AND PRESSURE DROP

300C Model	10°C Rise		20°C Rise	
	l/sec	kPa	l/sec	kPa
197	1.0	3.0	0.7	
3.0	0.5	3.0		
277	1.5	8.0	1.0	
4.0	0.7	3.0		
347	1.9	13.0	1.3	
6.0	0.9	3.0		
427	2.2	17.0	1.5	
8.0	1.1	4.0		

COLD WATER MAKE-UP/SUPPLY

Heating Heaters: We recommend that a cold water feed regulator (Pressure Reducing Valve) be installed and set at 50 kPa minimum pressure.

Backflow prevention in accordance with AS3600.4 may be required or alternatively a cold feed (header) tank may be used.

The minimum recommended height above the heater for such a tank is five (5) metres. Most systems operate at 100 kPa COLD.

Domestic Hot Water Heaters: These heaters are normally connected to a storage tank and the cold water supply must be fitted with a Pressure Limiting Valve, if the water supply pressure with 250 kPa added exceeds the pressure indicated on the tank.

PIPING

Heating Heaters: We recommend that all high points of the system be vented or fitted with automatic air vents.

The design of the system must be such that the heater is provided with adequate water flow and pressure at all times.

On radiator or heating systems where thermostatic valves can vary the water flow, then a suitable by-pass valve or loop must be fitted at the end of the system to keep the heater flow rate at an acceptable level.

IMPORTANT: When installing a new heater to an old system, it is a Raypak requirement that the system and its equipment be inspected and if necessary, drained and flushed out with clean fresh water, before the new heater is connected.

Failure to do this may cause blockages and/or heater damage which is NOT COVERED BY WARRANTY and any damage caused would result in extra costs to repair etc.

IF THERE ARE ANY DOUBTS ABOUT THE SYSTEM, DRAIN AND FLUSH AS A PRECAUTION.

Domestic Hot Water Heaters: If the heater is supplied as part of a package, including the tank and pump, the installation must comply with the drawing provided.

Failure to observe this requirement may result in an ineffective hot water capacity or damage.

For installation of the heater to an existing storage vessel we suggest that advice be sought to eliminate possible problems.

WATER QUALITY

The standard finned copper tube heat exchanger has proved to be very resilient and

capable of operating for many trouble free years on most reticulated water supplies.

Should your installation be in an area where "corrosive" or "hard" water is present, it would be advisable to contact Raypak before installation to ensure that the quality of the water is satisfactory.

DAMAGE CAUSED BY "CORROSIVE, HARD OR OTHERWISE POOR QUALITY WATER", IS NOT COVERED BY OUR WARRANTY,

We have produced a Hot Water Manual, which will be of assistance, check our website, for your free copy.

PRESSURE RELIEF VALVE(S)

There are three standard pressure relief valves available, 310kPa, 415kPa and 850 kPa. When sizing the valve, static head pressure must be taken into account to ensure that the PRV will not release during the heat up cycle.

When the heater is connected to a storage cylinder for Domestic Hot Water applications, a correctly sized and pressure rated PTR valve MUST be fitted to the cylinder.

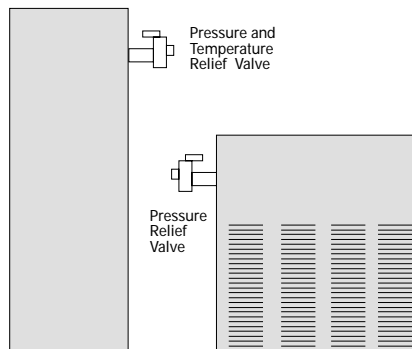

ELECTRICAL WIRING

Electrical power consumption of the heater is:

240 Volts AC, 50/60 Hz, less than 1 amp.

A normal 10 or 15 amp single phase power circuit should be suitable, Access to the electricals is achieved by removing the cover of the control panel.

The heater must be properly earthed and Raypak highly recommends the installation of an RCD (Residual Current Device) for added electrical safety. If the site is "electrically noisy", a mains filter can be supplied at extra cost, to eliminate any Microzone failures.

The heater must not be able to operate without the circulating water pump running.

The heater (240 Volts) power supply must be "interlocked" via the auxiliary contacts of the pump contactor (relay) etc., or alternatively the power supply for the pump and the heater must operate off the same circuit and isolation switch. (Parallel connection)

A Flow Switch is not an interlock and must not be used as one. If a Microzone control is fitted and the pump control is used, this is recognised as being interlocked with the heater. Rheem must approve any other form of interlocking.

A pump run on timer is required so that at any time that the heater is no longer required the heater shuts off and the pump continues for at least ten (10) minutes.

If a Microzone is installed and the pump control is used, this run on is included in the program.

For servicing purposes we suggest that the isolation switch be installed close to the heater. If there is any control wiring etc., which is not isolated by this switch then a suitable warning label must be affixed to the heater which will also direct the service person to the isolation switch for that particular wiring, (eg, more than one isolation switch is required to turn off the power supply, extra switch(es) on switchboard etc.)

Caution: Do not locate cables in front of or underneath the burner. Please consult Rheem for advice if unsure.

Where cables or conduit, trunking etc. are to be mounted on the heater casing, please keep at least 10mm air gap from the heater casing to eliminate possible overheating.

Do not locate cables etc. where they will restrict access covers, doors etc.

If a Microzone or any other PLC device is installed as part of the heater control etc. please observe the requirements for suitably screened data cable when utilising the

communication areas of these devices. Failure to do so will result in malfunctions and/or damage to the device, which will cause inconvenience to the user.

Failure of or damage caused to the Microzone or any other heater component due to incorrect wiring is NOT covered by our warranty and any repairs will be at extra cost.

There are many variations to the types of controls available and also RUN / FAIL indication can be supplied.

Advice on remote location of reset button and failure indication is available from your local representative or from Rheem.

COMMISSIONING

Warning: Commissioning must only be undertaken by a properly authorised and appropriately licensed person who is familiar with safe commissioning procedures. Check if the commissioning may require inspection by the gas supply authority.

1. Check that all necessary approvals and appropriate documents have been obtained.
2. Ensure that the heater is clean and the surrounding area is clear of all combustible and flammable materials.
3. Remove all liquids and chemicals from the plant room and check that combustion air openings are not obstructed. Chemicals must not be stored in the plant room. This is extremely dangerous and may damage the heater.
4. Fill the system with water and expel any air as required.
5. Purge all air from gas supply piping.

Caution: Liquid Propane Gas is heavier than air and sinks to the ground, exercise extreme care in lighting heater in confined areas.

6. Test ALL gas connections for leaks, using soapy water and a manometer.

(NOT A NAKED FLAME)

7. Conduct a visual inspection of the heater and equipment for any damage or installation problems and report as necessary
8. Check that the correct power supply is available and the circulation pump is electrically interlocked with the heater.
9. Check that the ventilation to the plant room complies with the requirements, of AS 5602/AG601 and local authority regulations.
10. If mechanical ventilation is provided, check its operation and any interlocks.
11. Check that the flue complies with the appropriate regulations and is fitted with an approved termination cowl.

12. Check that the gas supply is isolated and with the main gas valve isolation switch turned off, check the heater gas train and components for gas escapes.

13. Start the circulation pump and verify the flow switch operation (if fitted), then test the operation of the heater with no gas flow to confirm its operation up to the lockout status, then turn off the power.

14. Open the gas supply valve, switch on the power to fire the heater.

15. When the unit fires and reaches high fire, set the burner gas pressure to that shown on the data plate which is located on the front of the heater.

16. Verify that the high limit and any other safety devices are operating correctly.

17. Check that the flue is operating correctly or if there is evidence of down draft etc. Report as necessary.

18. Check operation of any water pressure relief valves etc. and set up the controls to desired settings.

19. Ensure that the customer is supplied with this manual and you have demonstrated the operation of the unit etc.

20. It is quite normal for the heater to produce some smoke and possibly condensation for the first thirty (30) minutes of firing from new.

WARNING: Should overheating occur or the fans fail to shut off, turn off the gas isolation valve adjacent to the heater and then examine the unit or call Rheem for advice.

PART 3 - SECTION II - OPERATING INSTRUCTIONS

LOCATION OF CONTROLS

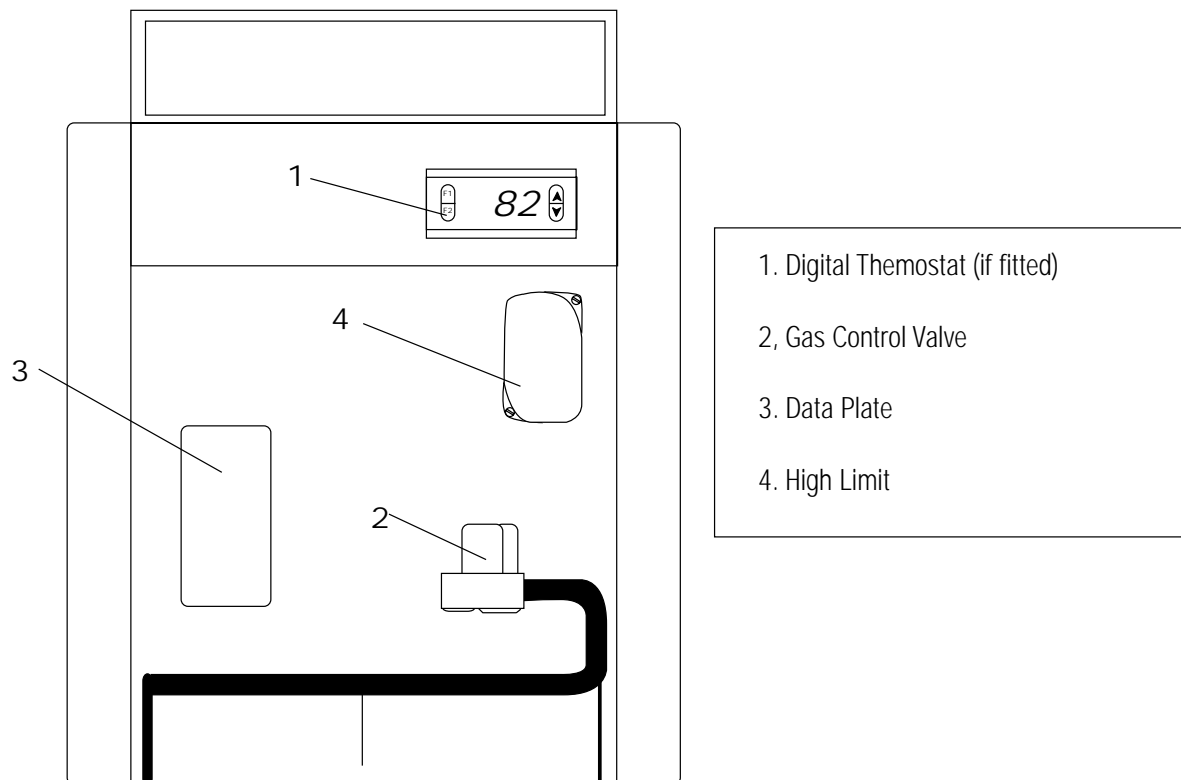

OPERATING CONTROLS:

Your new Raypak heater will have either MODULATING or ON/OFF controls.

MODULATING CONTROLS:

"NCM" model heaters are fitted with a modulating gas control valve. The purpose of this valve is to adjust the gas firing rate according to the required heating load and is usually installed on a heating system with radiators or a fan coil.

The temperature of the system water is controlled by matching the dial to the number, which corresponds to the charts below.

For the Robertshaw valve:-

Dial No.	Lo	1	2	3	4	5	6	7	8	Hi
Temp. C°	43	49	55	62	68	74	80	86	93	99

For the Honeywell modusnap valve:-

Dial No.	1	2	3	4	5	6	7	8	9
Temp. C°	66	70	74	78	83	87	91	95	99

HIGH LIMIT CONTROL

All heaters are fitted with a manual reset high limit switch. This control will shut down the heater in the event of a fault with the temperature control.

NOTE: The temperature of the high limit control and thermostat will be set up by the installer at the time of commissioning, to suit the individual requirements of your system. Further adjustments should not be necessary or should not be altered without consultation with your installer.

In the event of an overheat of the system water temperature, the high limit will trip. This will

shut off the heater. Should frequent resetting be necessary, a service technician should be called to check the system.

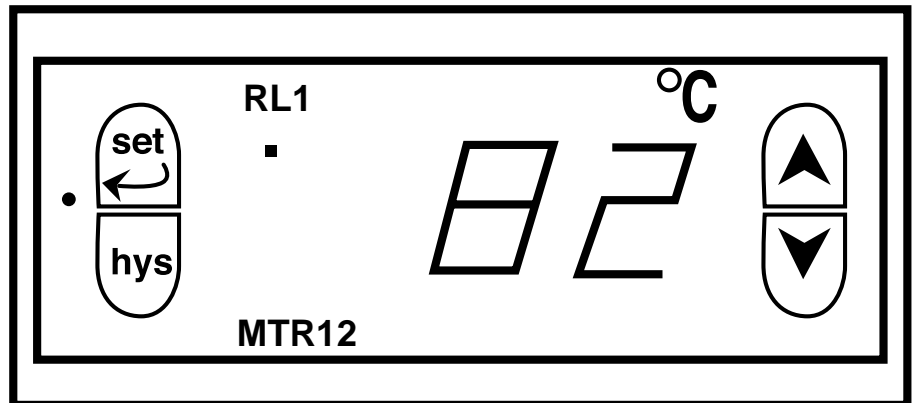

S thermostat which is programmed to operate in heating mode

ON/OFF CONTROLS

"NCO" model heaters are fitted with an adjustable controlling thermostat with its sensor located in the inlet side of the heater header, monitoring the system water temperature which in turn operates the heating cycle. This type of control is used where the system load is constant (eg. hot water supplied from a storage tank or in floor slab heating.)

The water temperature is controlled by setting the thermostat "set point".

NOTE: If your heater is supplied with a storage tank and a tank thermostat, the heater thermostat should be set slightly higher than that of the tank thermostat.

INSTRUCTIONS FOR USE OF LAE ELECTRONIC THERMOSTATS

Raypak uses the MTR12T1 RES thermostat, which is programmed to operate in the heating mode.

The only adjustments that should normally be required are: -

1 Set Point (set): - Which is the water temperature that you require

2 Differential (hys): - The difference between the thermostat turning OFF and then ON again when the temperature has fallen, (eg. 10°C would be ideal for a hot water heater.

To Adjust the Set Point: -

- Turn on the power supply to the heater.
- The digital display will show the actual water temperature.
- Press the "set" button, L1 will be displayed for 2 seconds.

- Then the Set Point temperature will be displayed.
 - By pressing the "UP" or "Down" button, you can set the desired temperature.
- To Adjust the differential: -**
- Turn on the power supply to the heater.
 - The digital display will show the actual water temperature.
 - Press the "hys" button, HY1 will be displayed for 2 seconds.
 - Then the valve will be displayed. (It must be a negative value.)
 - Press the "UP" or "DOWN" button to set your desired differential.
 - This is adjustable from 1 to 25 and relates to 10Cto250C.

Raypak may have programmed this thermostat to avoid any "nuisance" failures as: -

- vSP - (Min Set Point) 0°C - the heater won't operate if the water temperature is below setting.
- ^P - (Max Set Point) 95°C - the device turns off the heater if the temperature exceeds the setting
- rt!-(RL1 Rest Time) 0 min
- there is no delay in relay operation
- PF1 - (Probe Failure) OFF
- if the Probe (water sensor) fails, the relay will turn off the heater.
- AJD - (Probe Offset) 0°C
- the relay operates on actual temperature of the sensor.
- HY1 - (Mode) -25
- the negative value programs the device for heating.

To change the parameters): -

- Turn off the power supply
- Press and hold the "A" and "v" keys and then turn the power supply on.
- "Par" should be displayed
- Release the "A" and "v" keys.
- To access the required parameter and its setting press the "set" key,
- To change the value press the "A" or "v" key as required.
- To save this new value press the "set" key.

Should you require any further information please read the instruction sheet supplied with the unit or contact Rheem Australia.

WHAT IF YOU CAN SMELL GAS?

SAFETY INSTRUCTIONS

- **DON'T TRY TO LIGHT ANY GAS APPLIANCE.**
- **DON'T TOUCH OR OPERATE ANY ELECTRICAL SWITCH.**
- **TURN OFF THE GAS SUPPLY AT THE GAS METER OR ISOLATION POINT.**
- **CALL YOUR GAS SUPPLIER OR QUALIFIED GASFITTER FROM A NEIGHBOUR'S TELEPHONE.**

Use only your hand to turn the pilot gas control knob. Never use any tools.

If the knob will not turn by hand do not try to repair it, call a qualified service technician.

Force or attempted repair may result in a fire or explosion.

Do not use this heater if any part has been under water.

Call a qualified service technician immediately

to replace any part or control system that has been under water.

Always keep the heater clean and the surrounding area clear of all combustible and flammable materials.

Remove all dangerous liquids and chemicals from the plant room and check that the combustion air openings are not obstructed.

Chemicals must not be stored in plant room. This is extremely dangerous and also very damaging to the heater.

If you don't know what to do.

Ring for assistance.

LIGHTING PROCEDURE.

1. STOP read the safety information.
2. Turn heater ON/OFF power isolation switch to the "OFF" position.
3. Turn "OFF" any other electrical power to the heater. (If required)
4. Turn the gas supply valve, fitted next to the heater "OFF".
5. Wait 5 minutes to clear out any gas.

STOP!

If you smell gas, follow safety instructions.

If you do not smell any gas continue ...

6. This heater is equipped with an ignition device that automatically lights the burners.

Don't attempt to light the burner by hand.

7. Turn the gas supply valve to the "ON" position.

8. Turn on all electrical power to the heater. (If required)

9. Set the thermostat or temperature control to the desired temperature setting and turn the heater ON/OFF switch to the ON position.

10. The heater will go through its light up sequence.

If the heater fails and the "red" reset light illuminates, turn off the power supply, wait one (1) minute, turn the power supply back on and when the reset illuminates again, push the reset button, which will turn off the fail light and restart the light up sequence.

If heater still does not light, turn off gas and power supply and contact your qualified service technician.

TO TURN OFF THE HEATER

1. Turn the heater ON/OFF power isolation switch to the "OFF" position.

EMERGENCY SHUT-DOWN

1. Turn "OFF" the power supply to the heater
2. Turn "OFF" the gas isolation valve fitted close to the heater or the main gas supply.

AFTER START-UP WARNING

Should overheating occur or the gas supply fail to shut off, turn off the gas isolation valve located adjacent to the heater turn off the power supply switch and call for assistance.

VISUAL INSPECTION DANGER!

Keep the heater area free from chemicals, combustibles and flammable materials.

Do not obstruct the flow of ventilation air into the plant room.

Regularly clean the heater cabinet air louvres of any dust, lint and debris.

Failure to follow these safety precautions can cause fire, explosion, or asphyxiation.

With the heater turned on and heating, remove the door (if fitted) and make a visual check of the burners. The flame should be blue with a well-defined pattern.

A yellow or floating flame indicates restricted air openings, incorrect orifice size or possible excessive draft. Continual yellow flames indicate some restriction of the combustion air openings.

A bright orange, luminous flame is not normal and can cause sooting under prolonged operation.

Observe for any indication of soot. The presence of soot accumulation would indicate an abnormal operating condition.

Should any abnormalities occur, turn the heater off and contact your installer or service organisation.

WARNING: Operation of the heater when faulty will result in rapid and severe damage to the

heater, which is not covered by our warranty.

SERVICE ASSISTANCE

Service must only be undertaken by properly authorised personnel.

It is a requirement of all Raypak and all gas authorities that the heater be serviced at least once per year, where it is used in a specific application, e.g. heating, it would be practical to perform the service at the commencement of the heating season, or at any time there may be an indication of a problem.

This service should include the cleaning of the gas burners, inspection of waterways, and checking of all controls for correct operation.

It is important and very often will save time if you state the model number, serial number and type of gas used. This information will be found on the heater data plate.

Your local Raypak distributor will arrange for your service or recommend a qualified service organisation or visit:

www.raypak.com.au



RECOMMENDED SERVICE PROCEDURES

It is a Raypak requirement that all Raypak supplied equipment is serviced at least annually.

In some installations, due to the appliance location and/or workload it may be necessary to perform a service every six months.

RECOMMENDED SERVICE PROCEDURE FOR ANNUAL SERVICE.

- Isolate gas, electricity and water as required.
- Remove access covers and door(s) as required.
- Disconnect and remove Burner Tray.
- Dismantle and clean pilot assembly(ies), including injector(s).
- Clean and re-align electrode(s) and/or flame rod(s) and /or thermocouple(s).
- Clean main burner injectors and burner bars as required.
- Inspect, repair if minor and clean combustion chamber.
- Report on any major combustion chamber damage.
- Inspect external area of heat exchanger, clean fins and repair if minor.
- Check water seal area and report any damage.

- Operate Pressure Relief Valve (if Fitted) manually to check that the drain is clear and the valve reseals.
- Pool Heater: Remove and test Unitherm Governor(s), replace if faulty.
- Refit Burner Tray and reconnect gas train etc.
- Perform gas soundness tests to the gas train. (Any failures must be reported and repaired before recommissioning appliance.)
- Check all air vents and louvres, clean as required.
- Restore gas, electricity and water as required.
- Recommission unit, check and prove the operation of all safety devices.
- Check and monitor the operation of the appliance for at least ten (10) minutes.
- Refit access covers and doors as required.
- Clear and remove any dust and debris from the appliance and its immediate area.

RECOMMENDED SERVICE PROCEDURE FOR SIX MONTHLY SERVICE.

- Isolate gas, electricity and water as required.
- Remove access covers and doors as required.
- Restore the gas, electricity and water as required.
- Visually inspect main burner and pilot, check

operation if needed.

- If necessary, remove Burner Tray and service as required. (Refer to Annual Service).
- Check over the appliance thoroughly and report any damage immediately.
- Pool Heater: Remove and test Unitherm Governor(s), - (if faulty, Unitherm must be replaced before re-commissioning appliance).
- Check the heat exchanger and water seal areas and report any damage, if necessary.
- Check air vents and louvres, clean as required.
- Check operation of ignition system and all safety devices.
- Check operation and calibration of all temperature control devices.
- Check operation (and monitor the operation) of appliance for at least ten (10) minutes.
- Refit access covers and doors as required.
- Clean and remove any dust and debris from the appliance and its immediate area.

ONLY A SUITABLY LICENSED PERSON MAY PERFORM ANY REPAIRS, SERVICE AND/OR COMMISSIONING OF GAS APPLIANCES.

INSPECTION AND MAINTENANCE PROCEDURES

It is good practice to make periodical inspections of the heater, checking the operation of the controls and the burner etc.

It is recommended that the customer (owner) or user check the heater after the first and third months of operation, then at least once per annum.

It is also recommended to have a qualified service technician service the heater at least once per year, preferably at the start of the heating season, or at any time there may be an indication of a problem.

Danger: Keep the heater area free from chemicals, combustibles, and flammable materials. Do not obstruct the flow of ventilation air into the heater room. Failure to follow these precautions can cause fire, explosion or asphyxiation.

Clean the main burners and the heater cabinet air louvres of any dust, lint and debris. With the burner in operation, make a visual check of the burner flame and the pilot flame. Yellow flames indicate some restriction of the combustion air openings.

A bright orange, luminous flame is not normal and can cause sooting under prolonged operation. Should this condition be observed, contact your qualified service organisation to correct the problem.

Look for any indication of soot, the presence of soot accumulation would indicate an abnormal operating condition. This should be investigated and corrected by a qualified service organisation.

SERVICE ASSISTANT

Servicing must only be undertaken by a properly authorised person. It is a requirement of all Raypak and all gas authorities that the

heater be serviced at least once per year. It is recommended that the heater should be serviced at the start of each heating season.

This service should include the cleaning of the gas burners, inspection of waterways, and checking of all controls for correct operation.

It is important and very often will save time if you state the model number, serial number and type of gas used. This information will be found on the heater data plate. Your local Raypak distributor will arrange for your service or recommend a qualified service organisation.

Rheem Australia will arrange a service for your Raypak water heater.

Australia Service : 131 031

New Zealand Service : 0800 697 335

PART 4 - WARRANTY

LIMITED WARRANTY FOR HOT WATER HEATERS - MODELS BO109, BO147, BO197, BO277, BO347 & BO427 MCH, NCO

Rheem Australia Pty Ltd., (herein defined as Rheem) warrants to the original owner that the components of this hot water heater(s). Which are manufactured by Rheem to be free from defects in material and workmanship, when not misused or neglected, for a period of one (1) year from the date of shipment from factory plus thirty (30) days.

We are pleased to announce that the heat exchanger also has a FIVE-YEAR WARRANTY, which includes only the copper, bronze and cast iron waterways.

Field labour under warranty is included for a period of one (1) year from the same date and is applicable in Australian capital cities only.

Any costs associated with the shipping and transportation of parts are not covered by this warranty and remain the owner's responsibility.

Satisfactory Proof Of Purchase Is Required.

THIS WARRANTY WILL BE VOID IF THE HEATER DATA PLATE HAS BEEN ALTERED OR REMOVED.

ADDITIONAL WARRANTY EXCLUSION:

"To the extent permitted by law", this warranty does not cover failures or malfunctions resulting from:

- Failure to properly install, operate or maintain the heater in accordance with out printed instructions provided.
- Abuse, misuse, neglect, alteration, accident, fire, flood and the like. Examples of misuse or neglect include, but are not limited to, physical damage from external force, not following installation instructions, leaving door off for extended periods of time, etc.
- Sediment or lime build up, freezing, or other conditions causing inadequate water circulation.
- High velocity water flow exceeding heater design rates.
- Use of non-Rheem authorised accessories

or any other components used in conjunction with the heater.

- Failure to eliminate air from, or replenish water in, the connected water system.
- Chemical contamination of combustion air or use of chemical additives to the water.

PARTS REPLACEMENT:

"To the extent permitted by law", Rheem limits its liability at its option to:

In the case of supply of goods:

- (a) replacement of goods or the supply of equivalent goods; or
- (b) payment of the cost of replacing the goods or of acquiring equivalent goods; or
- (c) repair of the goods; and

In the case of services:

- (a) supply the services again; or
- (b) payment of the cost of having the services performed again.

Under this warranty, Rheem will furnish a replacement for any failed part. The failed part must be returned to Rheem, with all transportation charges prepaid and all applicable warranty conditions found to be satisfied. The replacement part will be warranted for only the unexpired portion of the original warranty.

MAKING A WARRANTY CLAIM:

"To the extent permitted by law", promptly notify the original installer, supplying the details of model number, serial number, date of installation and description of the problem. The installer must then notify his Rheem distributor for instructions regarding the claim. If either is not available, please contact:

Rheem Service 131 031

In all cases, proper authorisation must first be received from Raypak before any replacement of any part.

EXCLUSIVE WARRANTY - LIMITATION OF WARRANTY

Apart from the express warranties contained in this document and to the extent permitted by law, we will be under no liability to the customer (whether in contract, tort or otherwise), for any injury, loss or damages (including but not limited to incidental, special,

consequential or general damages) in connection with or arising out of supply or use of goods howsoever arising, whether or not caused by the negligence of us, our employees or agents. The company assumes no liability for consequential damages of any kind.

The term "consequential damages" includes, but is not limited to, loss of profit, loss of production, loss of revenue, cost of capital or losses of or damage to property or equipment, or loss of reputation."

This is the only warranty given by Rheem and no one is authorised to make any other warranties on Rheem's behalf.

We request that the postage paid warranty registration card be completed and returned within 14 days of purchase. Also complete the area on the front page of the operating and installation instructions and retain this certificate in the event that warranty is to be claimed.

NOTES

--



RHEEM SERVICE 131 031
WWW.RHEEM.COM.AU

Manufactured by
Raypak Australia
7 Geddes St.
Mulgrave Vic 3170
Ph. (03) 9535 3333
Fax (03) 9560 4974

